

PRELIMINARY VERSION !
(will be corrected)

REFERENCES OF DESIGN

This material includes only certain selected reference job orders,
while all displayed vehicles are at the status of the series production.



LINE Division

Design Centre,
Nábřeží 23, 741 01 Nový Jičín,
Czech republic

Tel.: +420 556 70 45 67

Fax: +420 556 70 16 70

E-mail: konstrukce@dytron.cz

<http://konstrukce.dytron.cz>

CUBINGS

The single-purpose cubings for checking individual parts

The single-purpose cubings have been used for checking an individual part against its closest vicinity. The single-purpose cubing is simulating vicinity, which may consist of several mutually linked parts.

Cubing of rear group lamp (design + production)

Vehicle: Škoda Octavia Combi (A4K)

Requestor: Škoda Auto a.s., Mladá Boleslav, CZ

Year: 1997

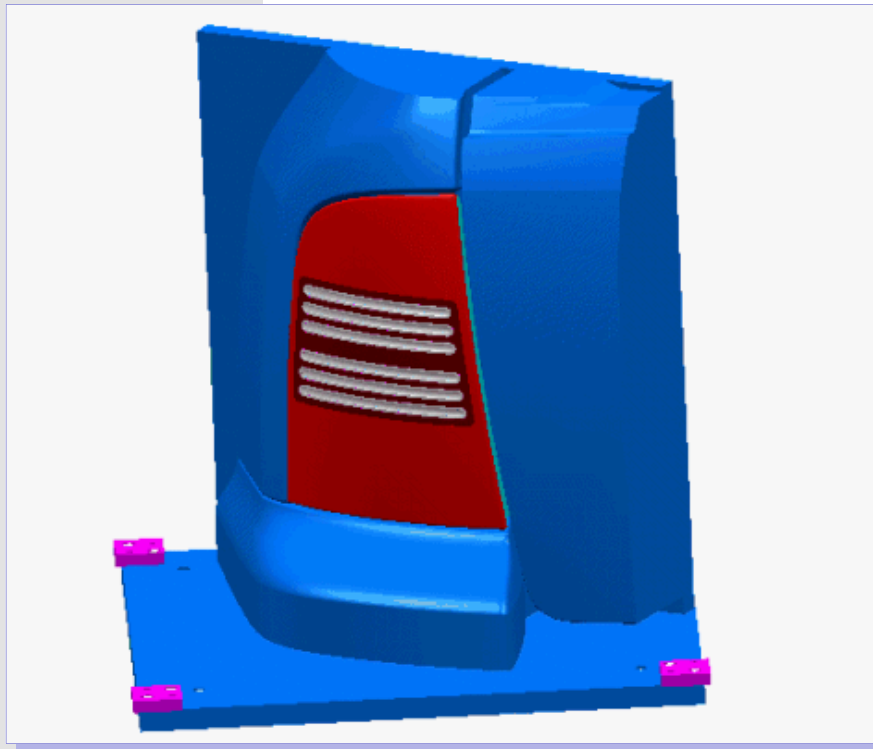

CUBINGS

The single purpose cubings for checking individual parts

Cubing for checking the hard top bar (design + production)

Vehicle: Škoda Octavia Combi (A4K)

Requestor: Škoda Auto a.s., Mladá Boleslav, CZ

Year: 1998

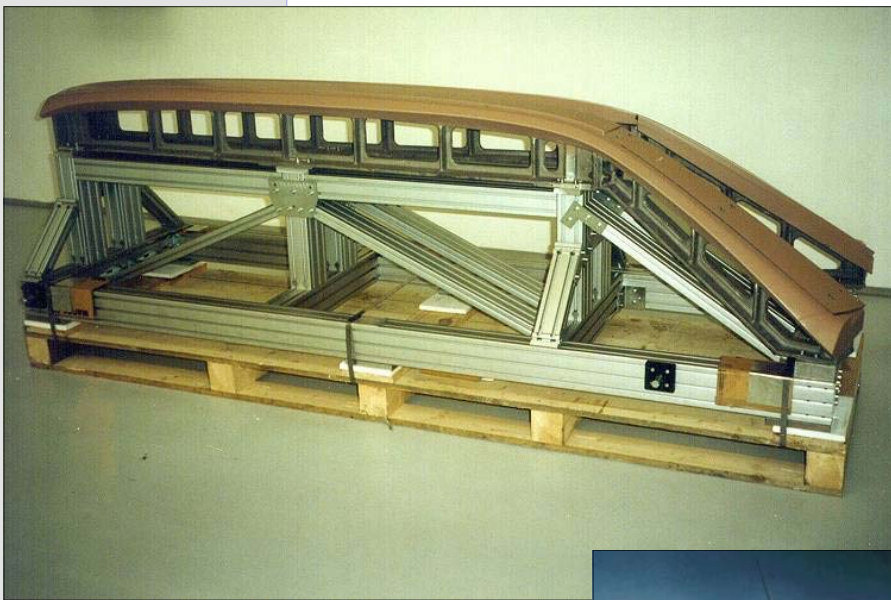
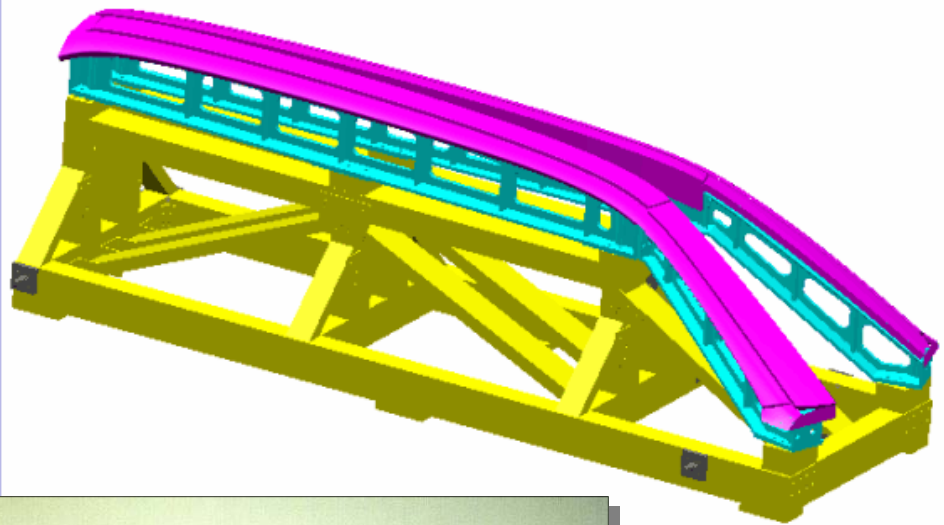

CUBINGS

The partial cubings

The partial cubings have been used for verification of layout precision of assembled parts of the body against its closest vicinity. The modular system of mutual exchange of reference and controlled parts has been applied in the partial cubings.

The partial cubing of the front part of the vehicle (design)

Vehicle: Volkswagen Golf (A5)
Requestor: Stola S.p.A., Torino, IT
Year: 2002

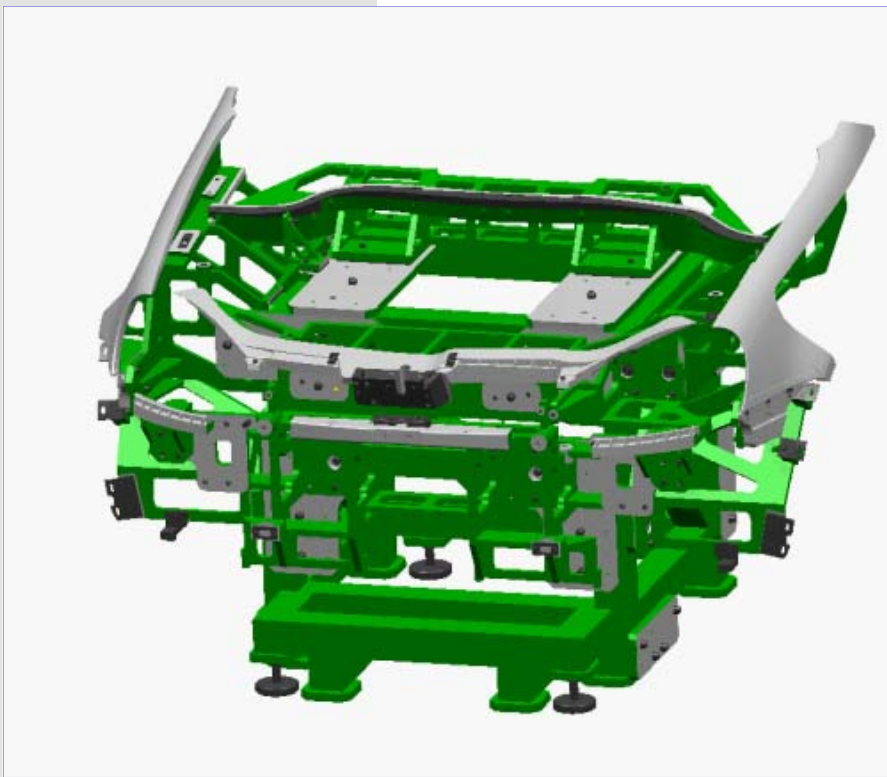

CUBINGS

The partial cubings

The partial cubing of the rear part of the vehicle (design)

Vehicle: Volkswagen Golf (A5)
Requestor: Stola S.p.A., Torino, IT
Year: 2002

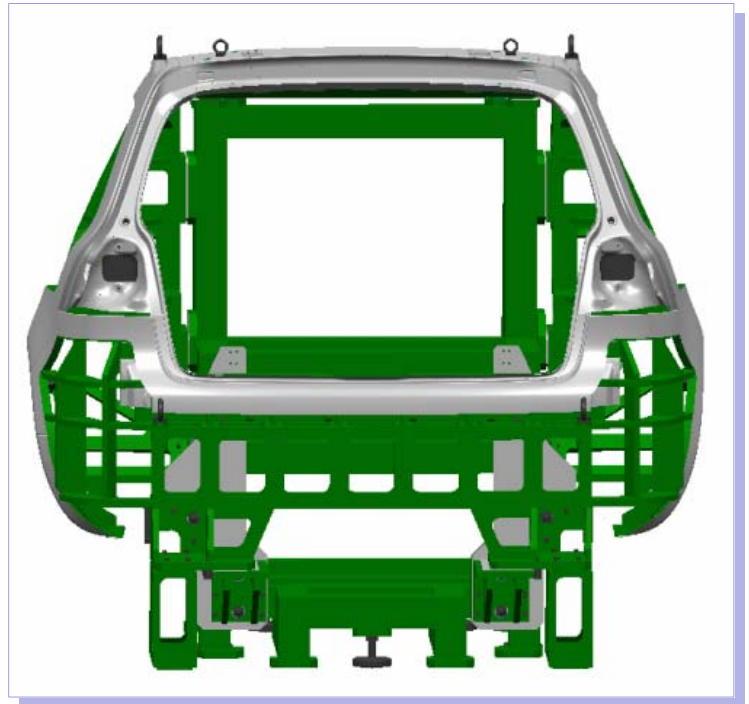

Other similar job orders:

The partial cubing of the instrument board (design)

Vehicle: Škoda Fabia (A04)
Requestor: Pininfarina Deutschland, Renningen, DE
Year: 1998

CUBINGS

The complete cubing of the vehicle – divided into the external and internal one

The cubings have been used for checking precision of dimensions and shape of assembled parts (moulded parts, plastic parts) and of the welded parts of the body. The modular system has been applied enabling to exchange the nominal and checked part while subsequently checking the part against its vicinity. The pieces of equipment concerned are 2 separate systems for checking external and internal parts of the vehicle.

The external + internal cubing of the whole vehicle (design + partial production)

Vehicle: Škoda Superb (B5)

Requestor: Pininfarina Deutschland, Renningen, DE

Year: 2001

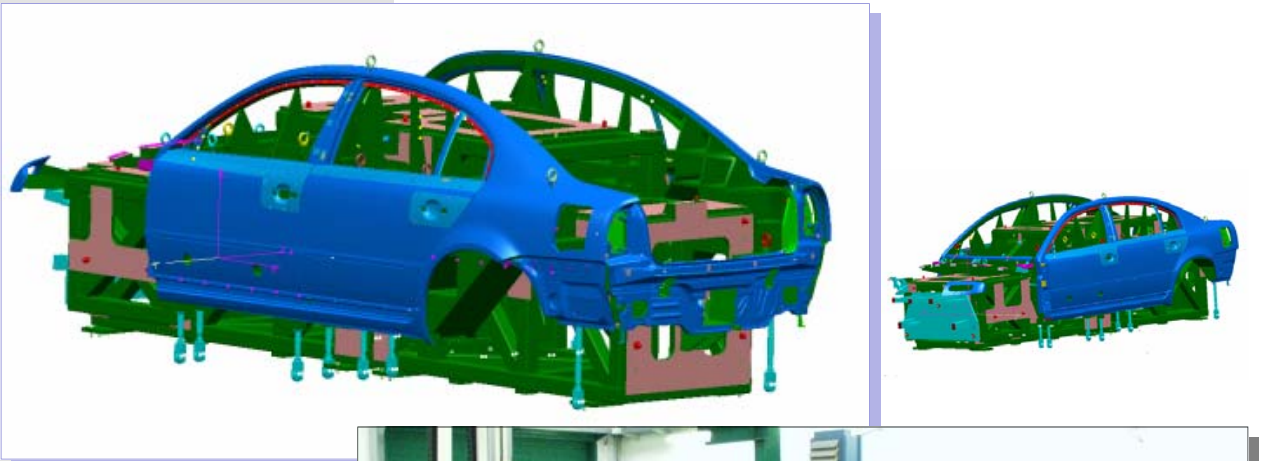

CUBINGS

The complete cubing of the vehicle – divided into the external and internal one

The external + internal cubing of the whole vehicle (design + partial production)

Vehicle: Škoda Fabia—all models (standard, combi, sedan) (A04)

Requestor: Pininfarina Deutschland, Renningen, DE

Year: 1998–2000

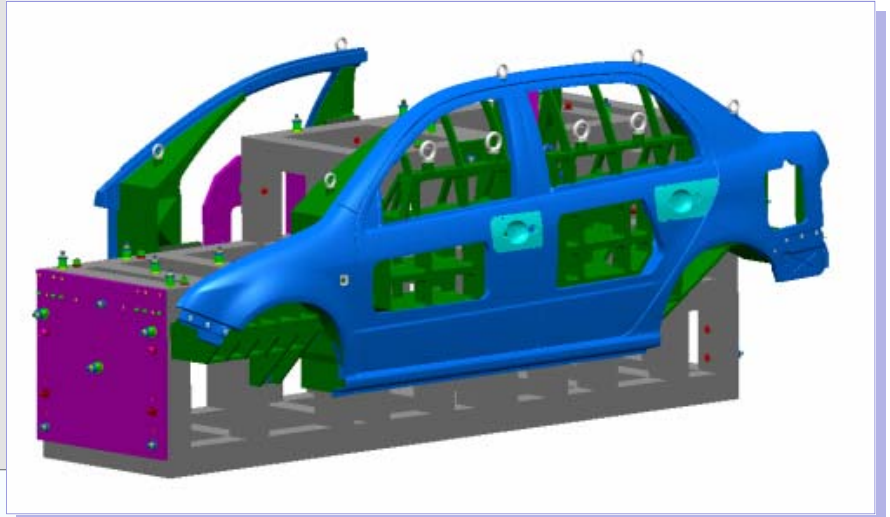

CUBINGS

The complete cubing of the vehicle – divided into the external and internal one

The external + internal cubing of the whole vehicle (design + partial production)

Vehicle: Škoda Fabia—all models (standard, combi, sedan) (A04)

Requestor: Pininfarina Deutschland, Renningen, DE

Year: 1998–2000

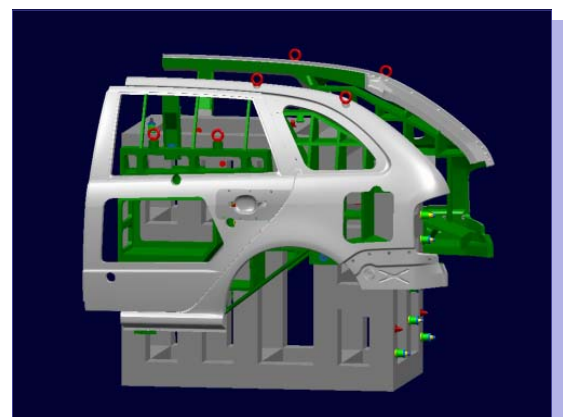
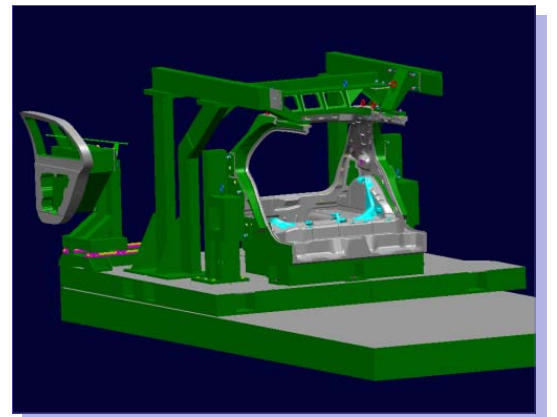
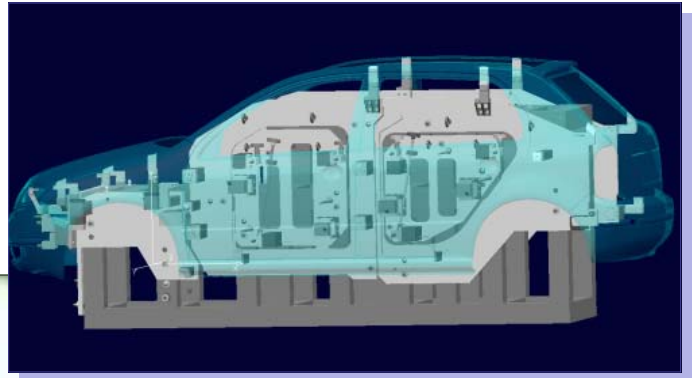

CUBINGS

The complete cubing of the vehicle – divided into the external and internal one

The list of implemented divided cubings:

The external + internal cubing of the whole vehicle (design + partial production)

Vehicle: Škoda Fabia (A04)

Requestor: Pininfarina Deutschland, Renningen, DE

Year: 1998

The external + internal cubing of the whole vehicle (design + partial production)

Vehicle: Škoda Fabia Combi (A04K)

Requestor: Pininfarina Deutschland, Renningen, DE

Year: 1999

The external + internal cubing of the whole vehicle (design + partial production)

Vehicle: Škoda Fabia Sedan (A04S)

Requestor: Pininfarina Deutschland, Renningen, DE

Year: 2000

The external + internal cubing of the whole vehicle (design)

Vehicle: BMW–Rover off road

Requestor: Pininfarina Deutschland, Renningen, DE

Year: 2000

The external + internal cubing of the whole vehicle (design)

Vehicle: Saab Cabrio (442)

Requestor: Staufen Engineering, Süssen, DE

Year: 2001

The external + internal cubing of the whole vehicle (design + partial production)

Vehicle: Škoda Superb (B5)

Requestor: Pininfarina Deutschland, Renningen, DE

Year: 2001

The external + internal cubing of the whole vehicle (design + partial production)

Vehicle: Škoda Octavia (A5)

Requestor: Stola S.p.A., Torino, IT

Year: 2002

The external + internal cubing of the whole vehicle (design)

Vehicle: Volkswagen Golf (A5)

Requestor: Stola S.p.A., Torino, IT

Year: 2002



CUBINGS

The complete cubing of the vehicle - external and internal combined

These cubings have been used for checking both purchased parts and moulded parts including welded parts of the body. The modular system has been applied which enables to exchange the nominal and checked part while subsequently checking such part against its vicinity. In this case, there is only one equipment used for checking external and internal parts of the vehicle.

The external + internal cubing of the whole vehicle (design)

Vehicle: Proton GXM
Requestor: Stola S.p.A., Torino, IT
Year: 2003

Other similar job orders:

The external + internal cubing of the whole vehicle (design)

Vehicle: Volkswagen Transporter (T5)
Requestor: Staufen Engineering, Süssen, DE
Year: 2001

The external + internal cubing of the whole vehicle (design)

Vehicle: Proton 2
Requestor: Stola S.p.A., Torino, IT
Year: 2003



DATA CONTROL MODELS

The single purpose DKM for checking individual parts

The single purpose DKM have been used for visual check of the individual part design. It is usually produced as a dummy of scale 1:1.

DKM of the rear group lamp (design + production)

Vehicle: Volha

Requestor: Hella s.r.o., Mohelnice, CZ

Year: 1998

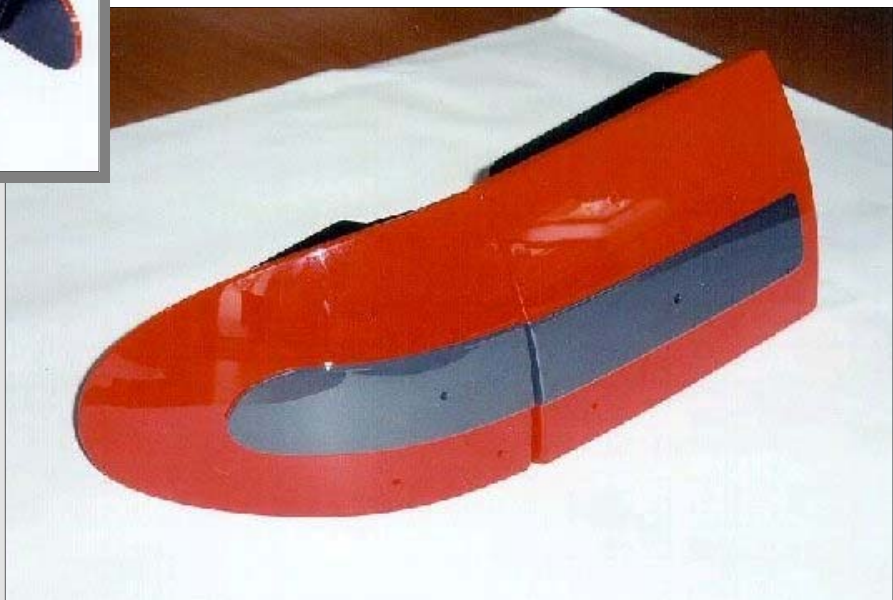
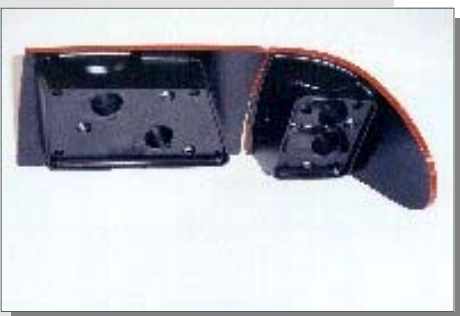

DATA CONTROL MODELS

The complete DKM for checking the whole vehicle

It has been used for verification of data accuracy of individual parts of the vehicle and for styling assessment of the complete vehicle design.

DKM of the complete vehicle (design)

Vehicle: Volkswagen Touareg (Colorado)

Requestor: Pininfarina Deutschland, Renningen, DE

Year: 1999

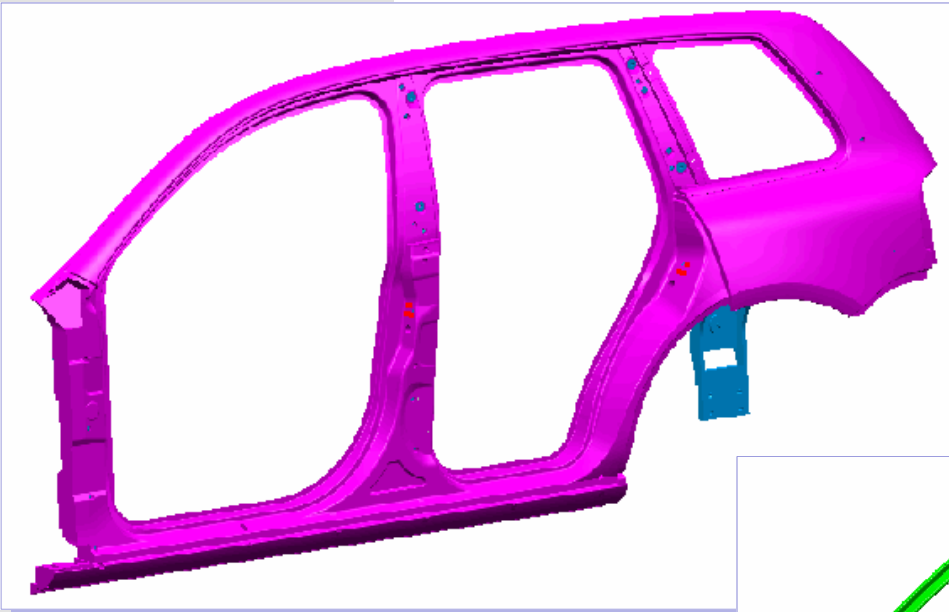

PRODUCTION TOOLS

Pressing tools

Via gradual steps, the pressing tools enable to form a pressed product of required shapes and characteristics from the metal sheet.

Pressing tool for operation 50—hard top: cut-out for the hard top window (design)

Vehicle: Škoda Octavia (A5)

Requestor: Fredex Projects, Ledec nad Sázavou, CZ

Year: 2001

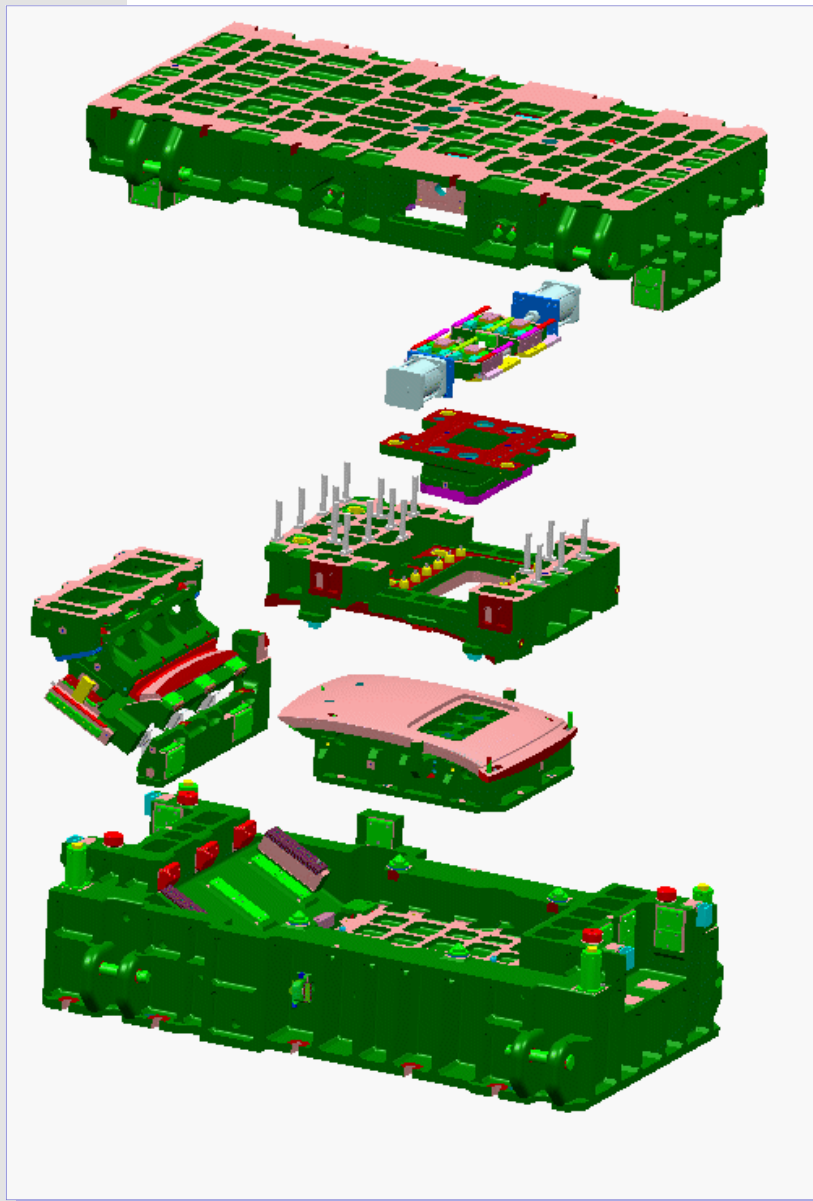

Other similar job orders:

Pressing tool for operation 50—front bonnet (design)

Vehicle: Škoda Octavia (A5)

Requestor: Fredex Projects, Ledec nad Sázavou, CZ

Year: 2001

FIXTURES

Check fixtures

Check fixtures have been used for locating a part into the required position and subsequent check of the shape durability including measurement of parts mainly produced in the series production.

Fixture for checking air-conditioning hose (design + production)

Vehicle: Ford Fiesta

Requestor: Autopal s.r.o., Nový Jičín, CZ

Year: 1998

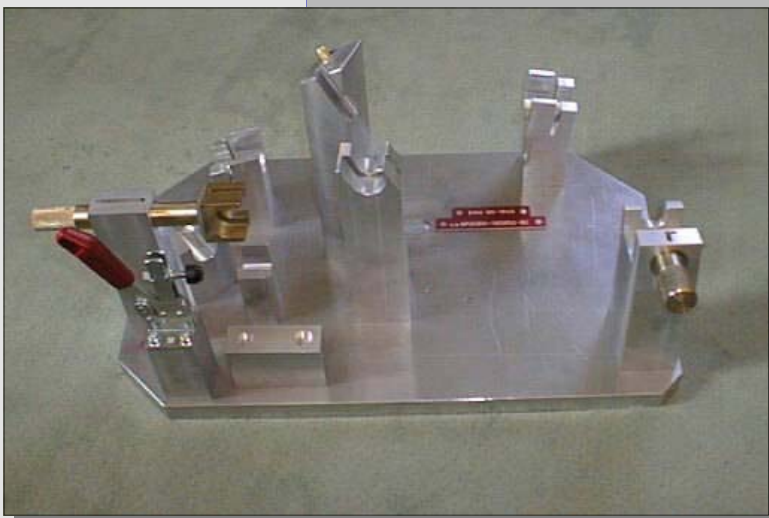
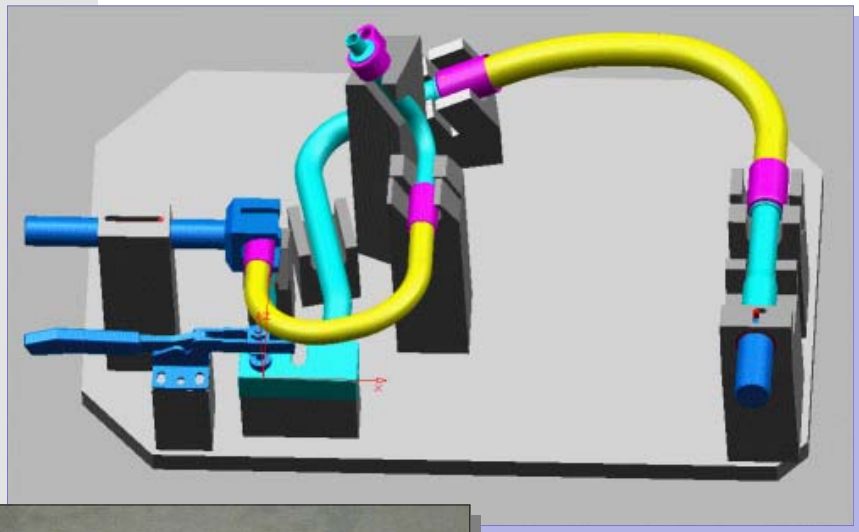

Other similar job orders:

Dozens of check fixtures for inspection of various parts of vehicles of different makes, for example:

Fixture for checking the shape of the air-conditioning hose (design + production)

Vehicle: Peugeot C5

Requestor: Autopal s.r.o., Nový Jičín, CZ

Year: 2002

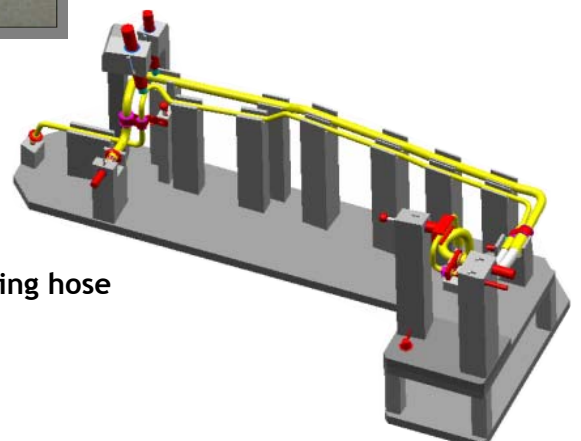

FIXTURES

Assembly fixtures

Fixtures for precise positioning of the assembled parts and performance of the specified assembly operation.

Fixture for application of glue of the front lamp (design)

Vehicle: Ford Fiesta

Requestor: Derutex s.r.o., Příbor, CZ

Year: 2000

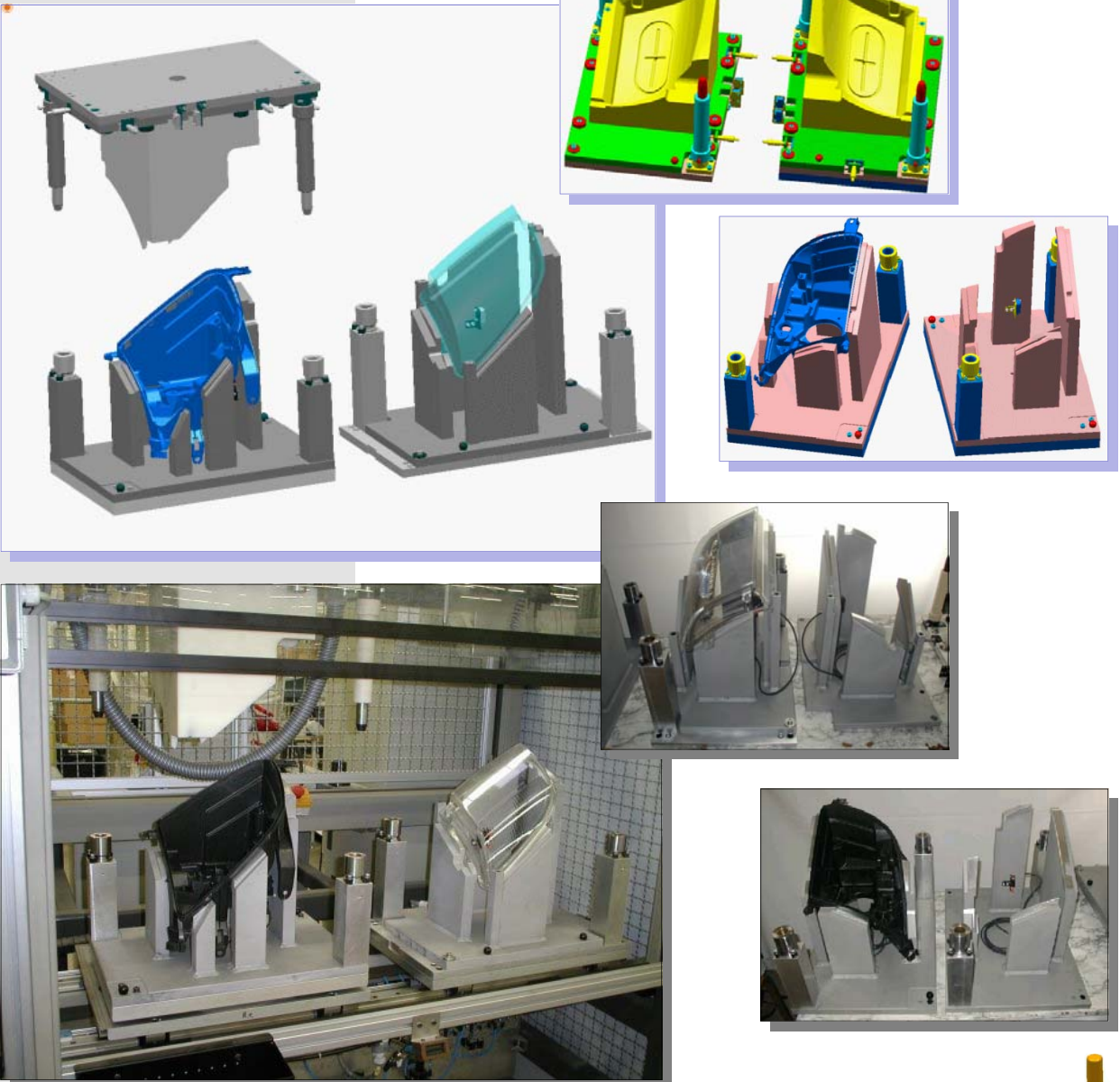

Other similar job orders:

Fixture for increased precision of the assembly of the seal bar of the door lining (design + production)

Vehicle: Volkswagen Touareg / Porsche Cayenne

Requestor: LEAR Slovakia s.r.o., Bratislava, SK

Year: 2003

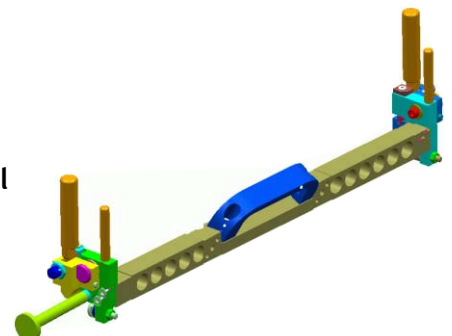

FIXTURES

Measuring fixtures

These are determined for location of checked parts, if need be of sub-groups of the body into a required position (RPS points defined in the documentation) for the purpose of checking the shape preciseness.

Fixture for measurement of the rear group lamp (design + production)

Vehicle: Ford Focus Hatchback

Requestor: Autopal s.r.o., Nový Jičín, CZ

Year: 1998

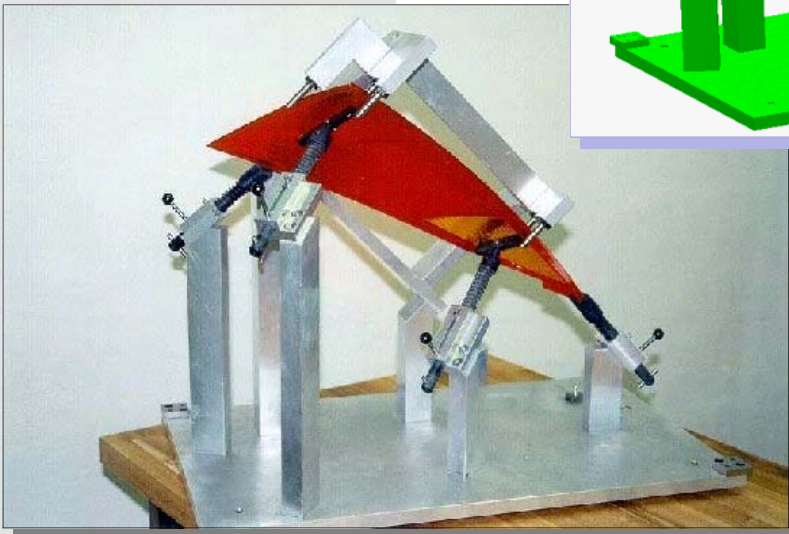
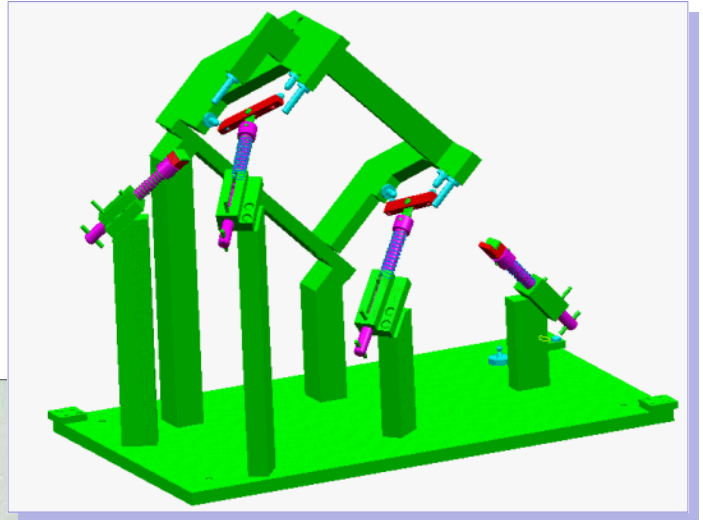

Other similar job orders:

Dozens of check fixtures for measurement of various parts of vehicles of different makes, for example:

Fixture for measurement of side plate

(design + production)

Vehicle: Škoda Superb (B5)

Requestor: Škoda Auto,
Mladá Boleslav, CZ

Year: 2002

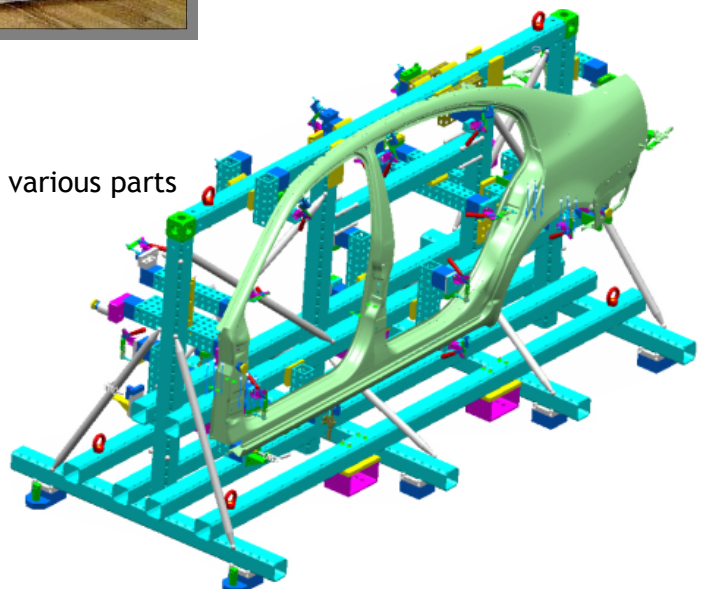

FIXTURES

Positioning fixtures

They have been used, as in case of measuring fixtures, for the location of the part being checked into the required position during dimension check with 3 D measuring device, but the part being checked does not need to be fixed in RPS points (as opposed to measuring fixtures).

Fixture for location of the front door (design + production)

Vehicle: Škoda Superb (B5)

Requestor: Škoda Auto, Mladá Boleslav, CZ

Year: 2002

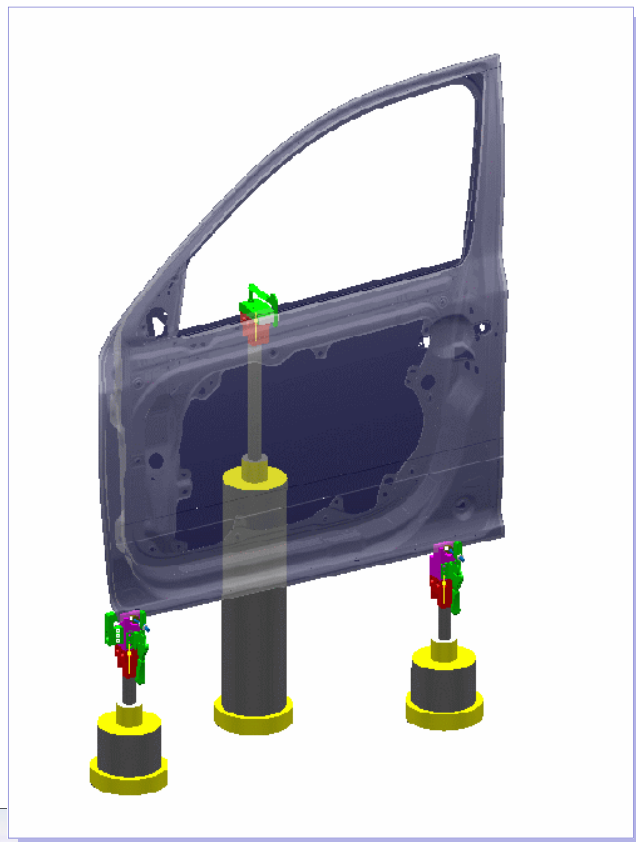

Other similar job orders:

Dozens of positioning fixtures for the location of various parts of vehicles of different makes.

FIXTURES

Transport fixtures

They have been used for easier handling and warehousing of cubing parts and measuring fixtures.

Fixtures pro transport of cubing parts (design + production)

Vehicle: Škoda Fabia, Octavia, Superb

Requestor: Škoda Auto, Mladá Boleslav, CZ

Year: 1998-2003



Other similar job orders:

Dozens of transport fixtures for transport of various parts of vehicles of different makes.

FIXTURES

Welding fixtures

They have been used for a clear location and robust fix of the parts being welded in the welding line. They might be geometrical (for precise positioning of individual metal sheets or inter-groups) or welding (to complete other welding points).

Welding stations for the rear wheel arch (design)

Vehicle: Škoda Octavia (A5)

Requestor: EDAG K.f.t., Győr, HU

Year: 2003

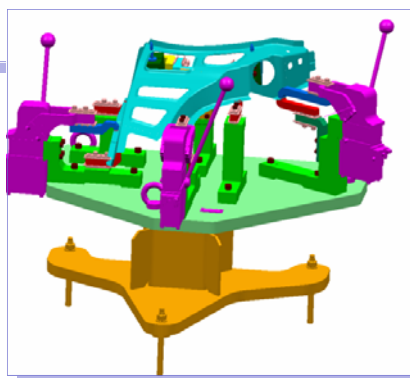
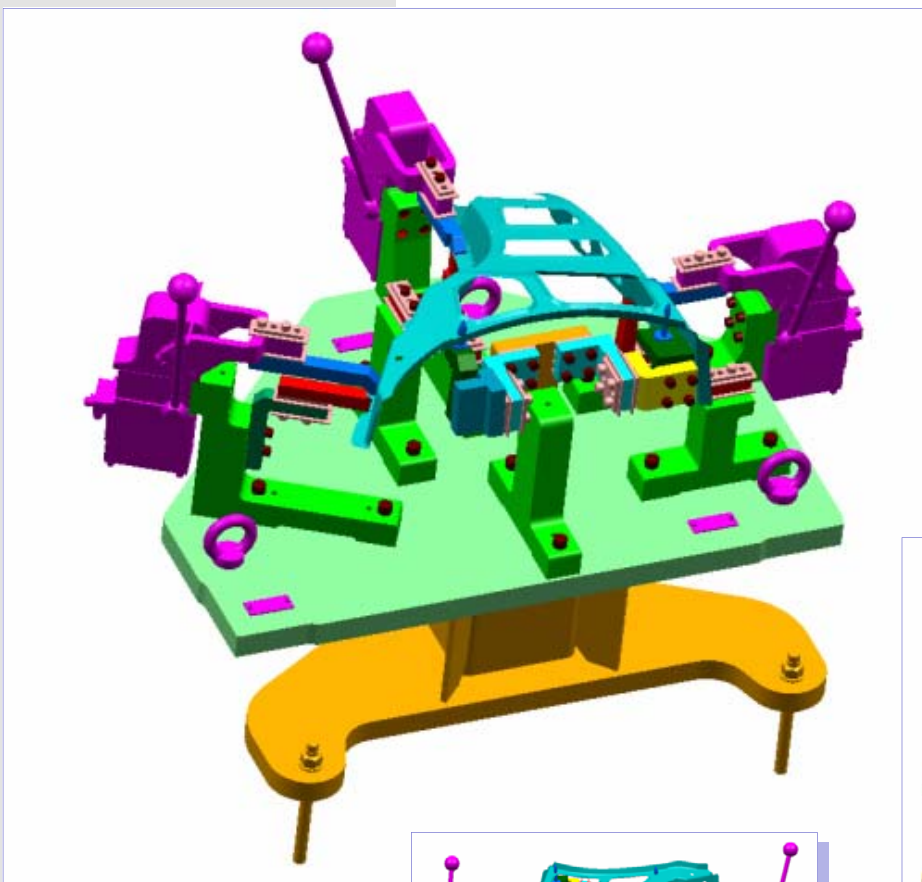

Other similar job orders:

Dozens of welding fixtures for welding of various parts of vehicles of different makes.

FIXTURES

Welding fixtures - handling and auxiliary fixtures

Grasping and handling fixtures belong to other group and have been used for handling the weldment during location and removal from the welding fixture while passing it onto next welding operation or to the container, or if need be, for the completion of an auxiliary operation (for example punching).

Various welding fixtures from the following job order:

Vehicle: Daimler Chrysler W161

Requestor: Staufen Engineering, Süssen, DE

Year: 2003

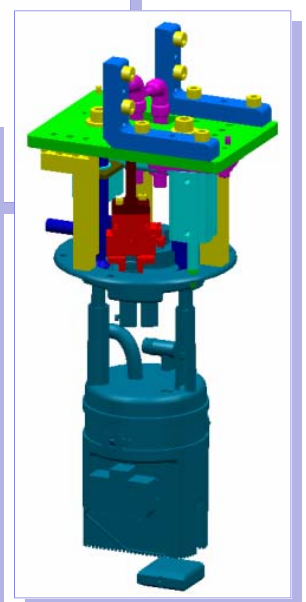
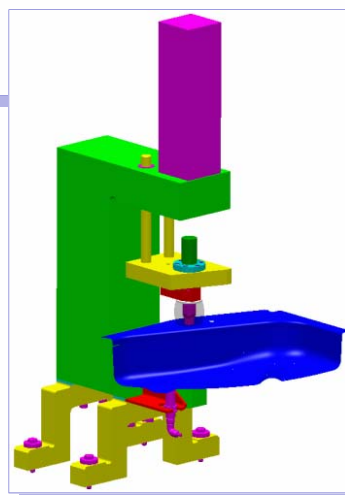
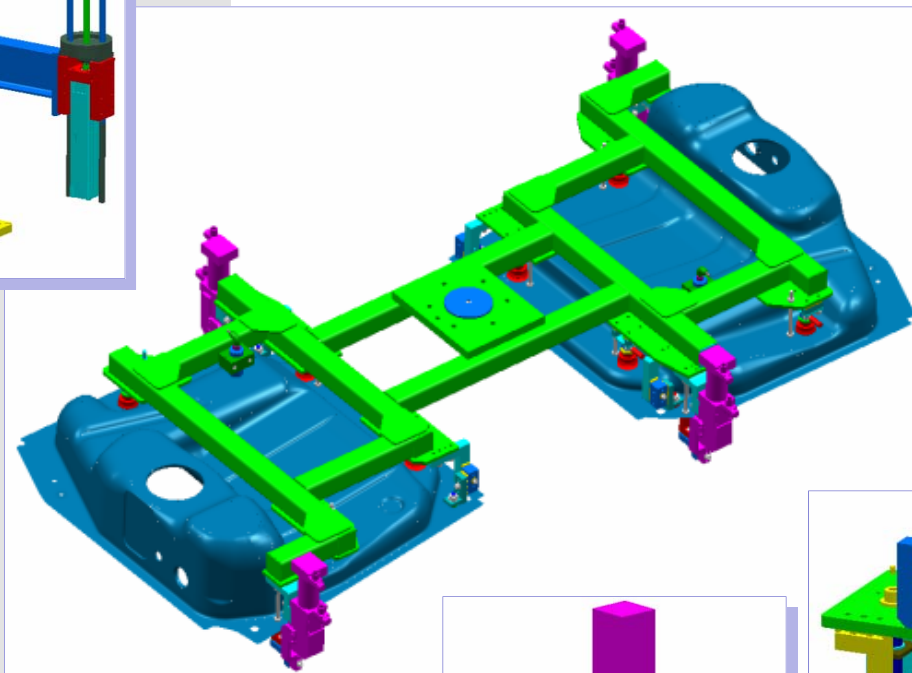
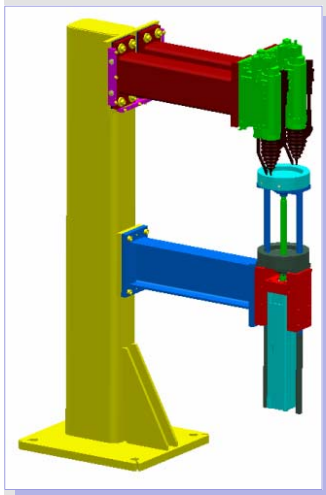

Other similar job orders:

Dozens of welding fixtures for welding of various parts of vehicles of different makes.

DYTRON s.r.o.

Na Valech 411/1, 741 01 Nový Jičín,
Czech republic

Tel.: +420 556 704 545

Fax: +420 556 704 747

E-mail: dytron@dytron.cz

<http://www.dytron.cz>